

US INSTALLATION INSTRUCTION— POWER & POWER HEATED MIRROR ASY- REAR VIEW OUTSIDE

E INSTRUCCIONES DE MONTAJE — CONJUNTO DE ESPEJO TÉRMICO ELÉCTRICO - RETROVISOR EXTERNO

F NOTICE DE MONTAGE — RÉTROVISEUR EXTÉRIEUR TÉLÉCOMMANDÉ ET CHAUFFÉ

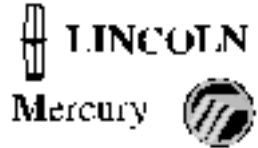

Subject to alteration without notice
Reservados modificaciones técnicas
Sous réserve de modifications techniques

2000	1999
EXCURSION	SUPERDUTY 250/350



PERSONAL INJURY
LESIONES PERSONALES
RISQUE DE BLESSURE



VEHICLE DAMAGE
DAÑO DE VEHICULO
DOMMAGE AU VEHICULE



INCORRECT
INCORRECTO
INCORRECT



CORRECT
CORRECTO
CORRECT



SEE MANUAL
VER MANUAL
VOIR LE MANUAL

A RH	B LH
C RH 1999 - 2001	D LH 1999 - 2001

TOOLS REQUIRED
HERRAMIENTAS NECESARIAS
OUTILS NÉCESSAIRES

TORQUE WRENCH
LOS TORQUE TIRAN DE
CLÉ DYNAMOMÉTRIQUE



5.5mm

7mm

8mm

11mm



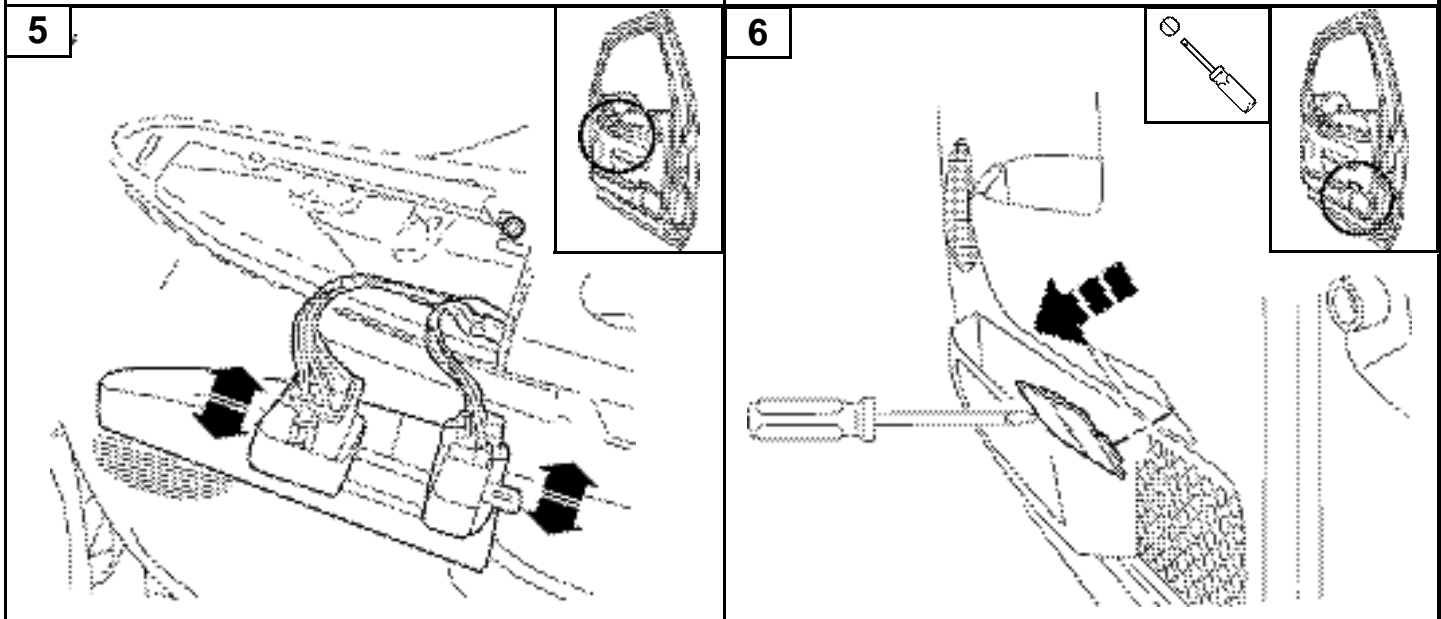
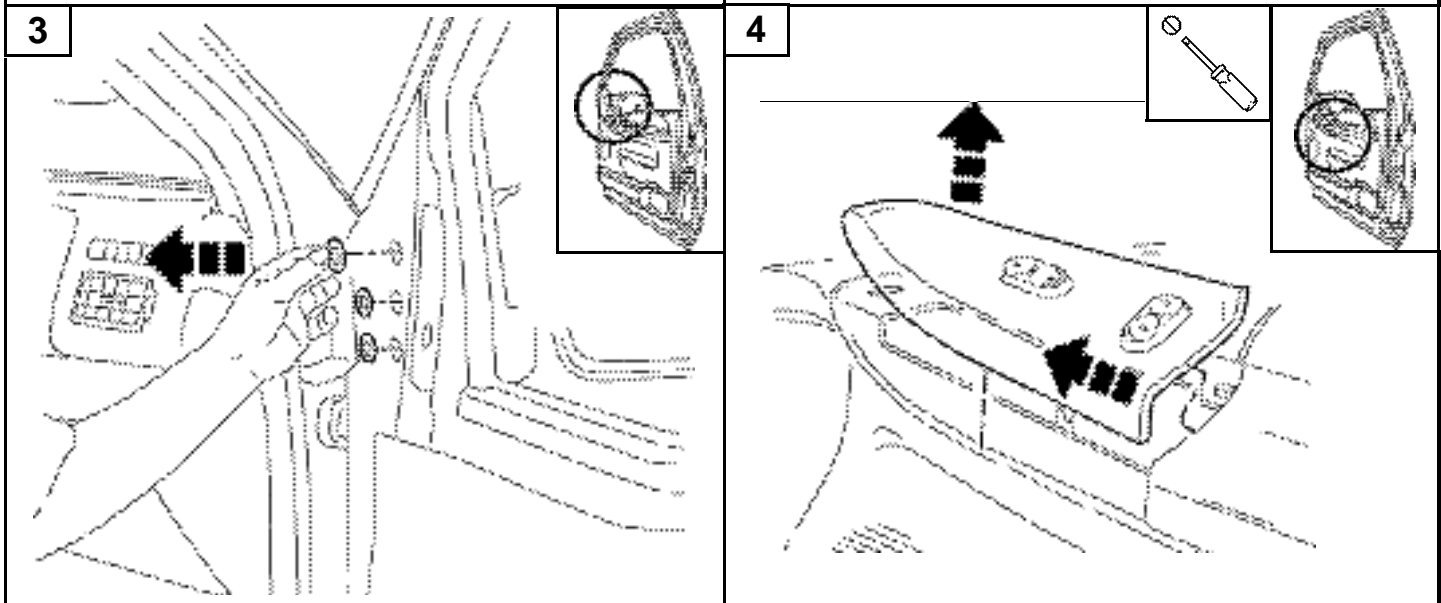
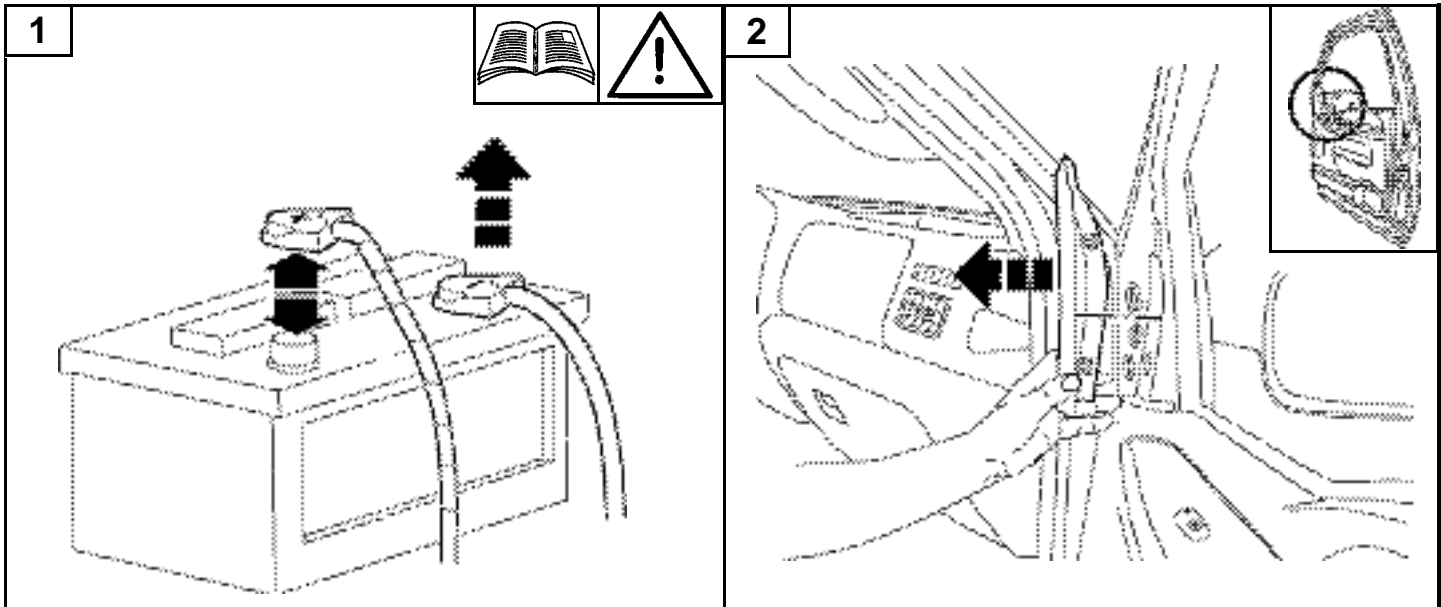

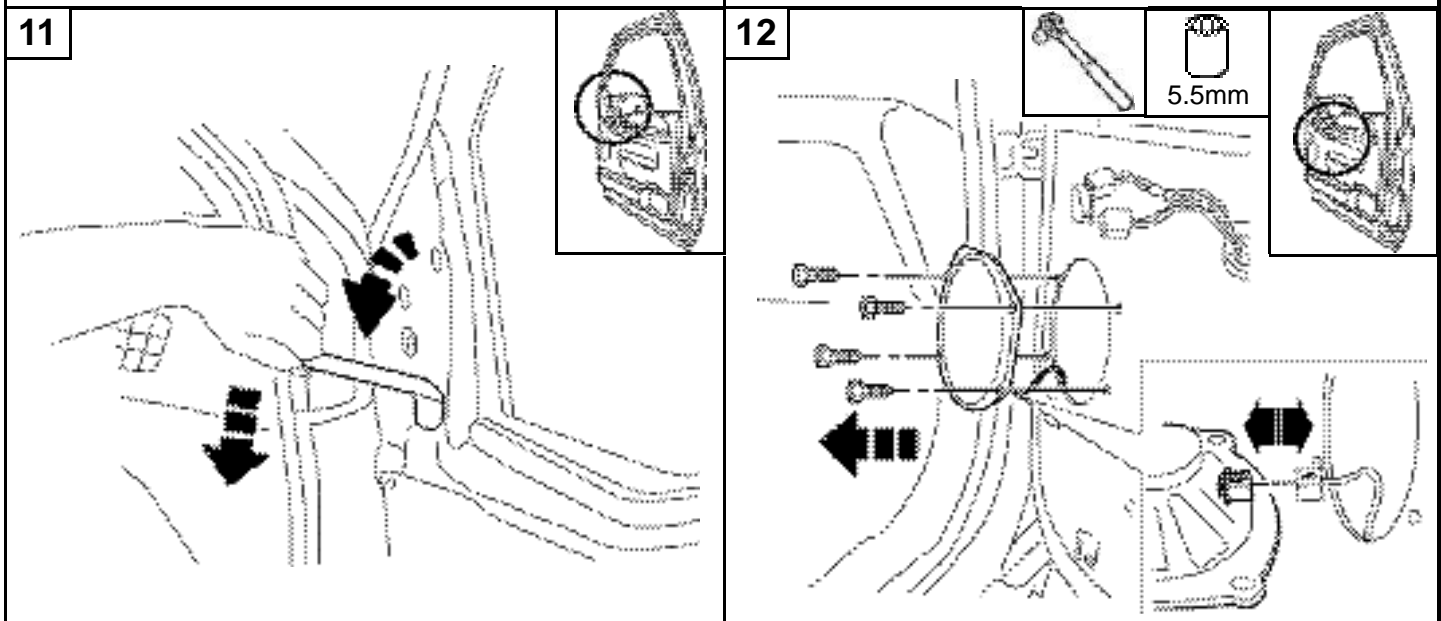
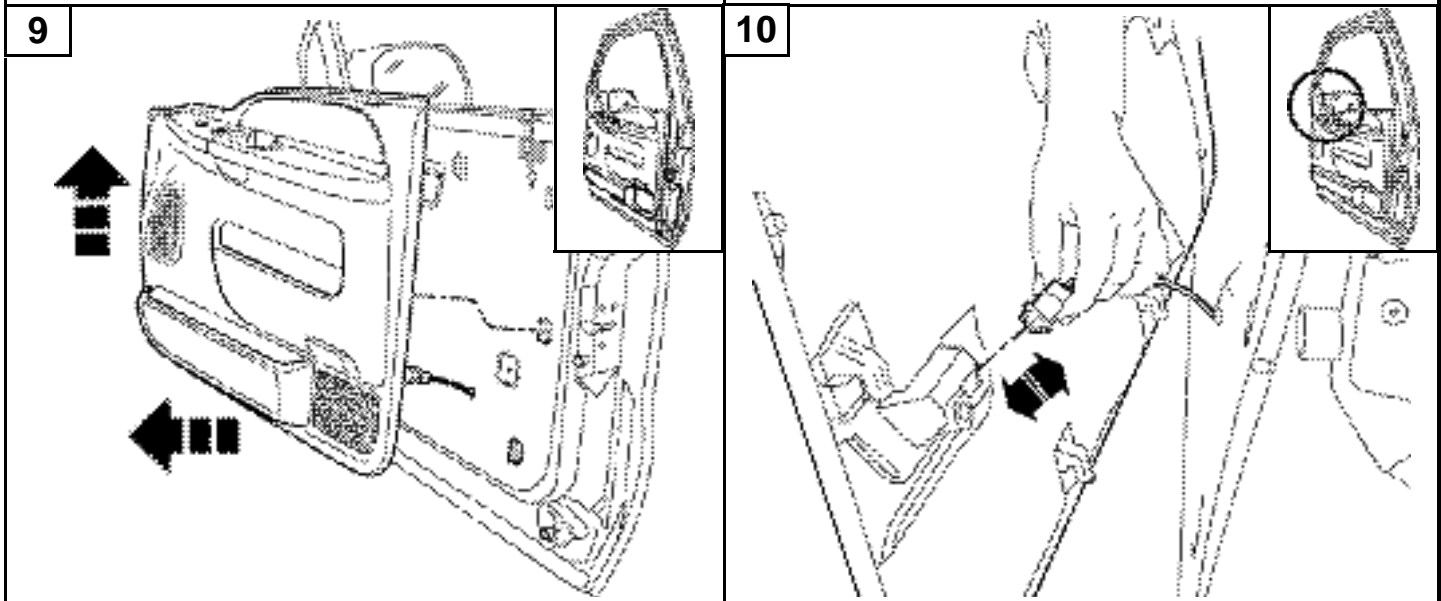
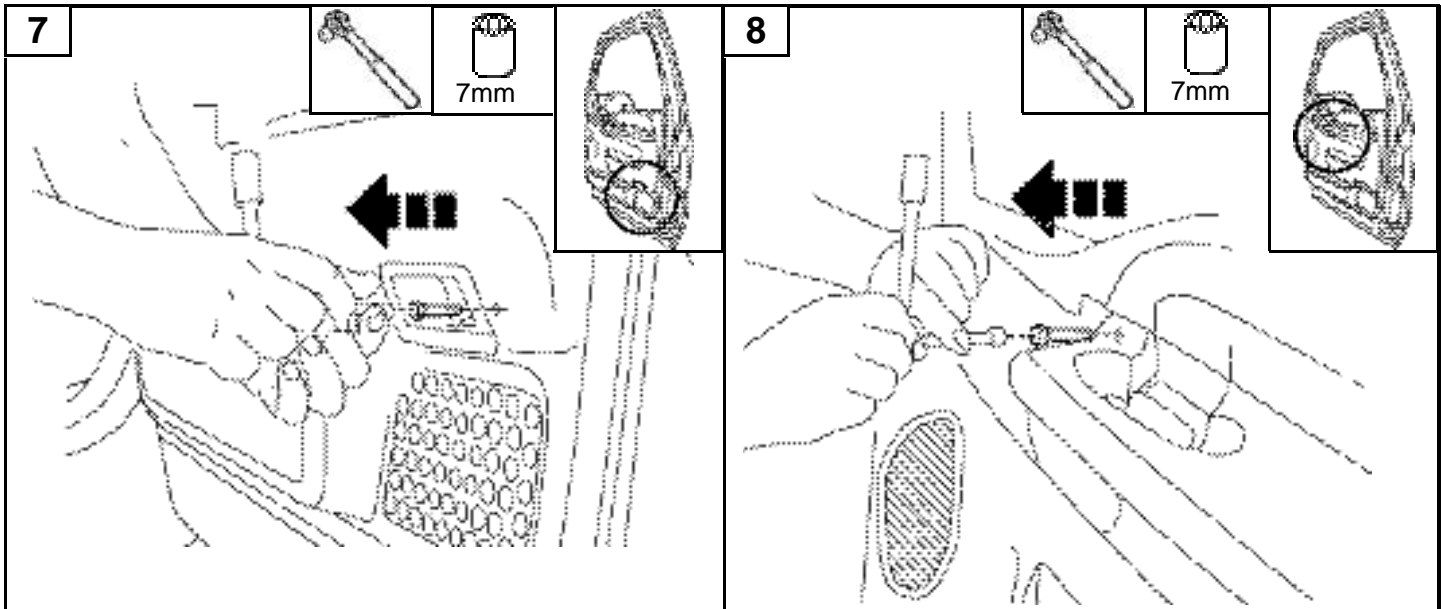

13

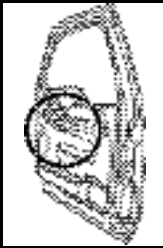
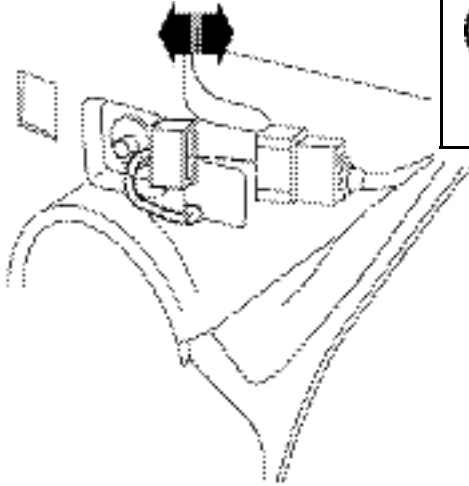

14

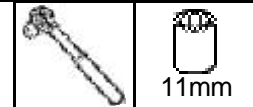
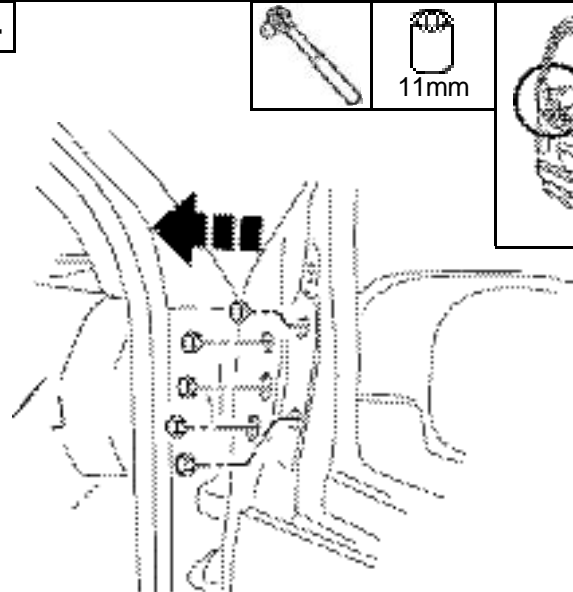

15

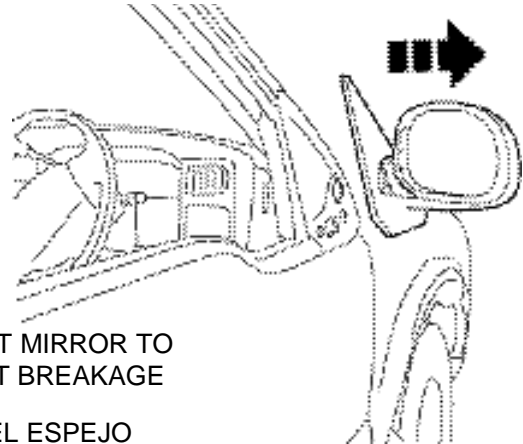

SUPPORT MIRROR TO PREVENT BREAKAGE

APOYE EL ESPEJO PARA EVITAR ROTURAS

SOUTENIR LE MIROIR POUR ÉVITER DE LE BRISER

16a

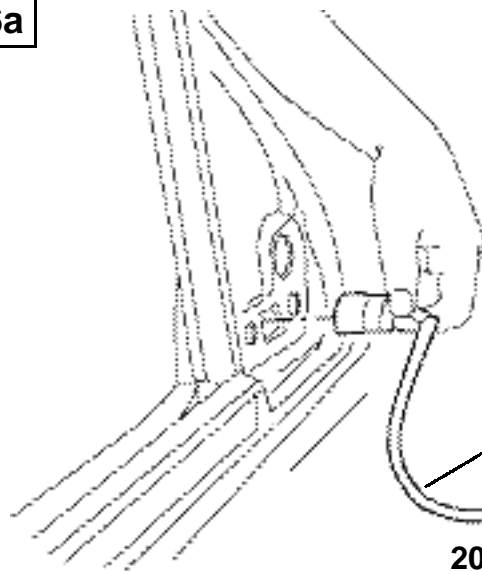

2001

17a

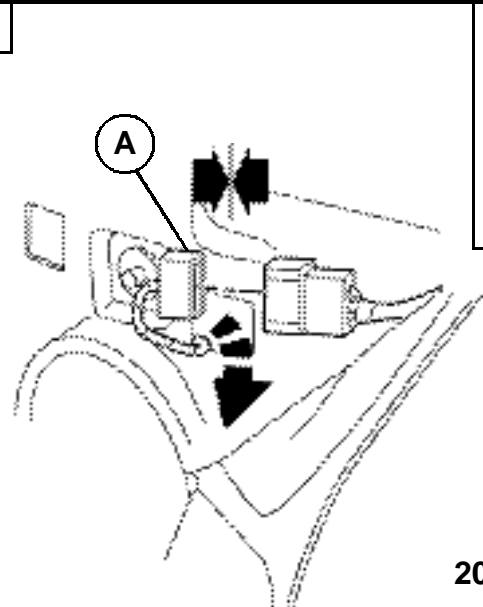

2001

16b

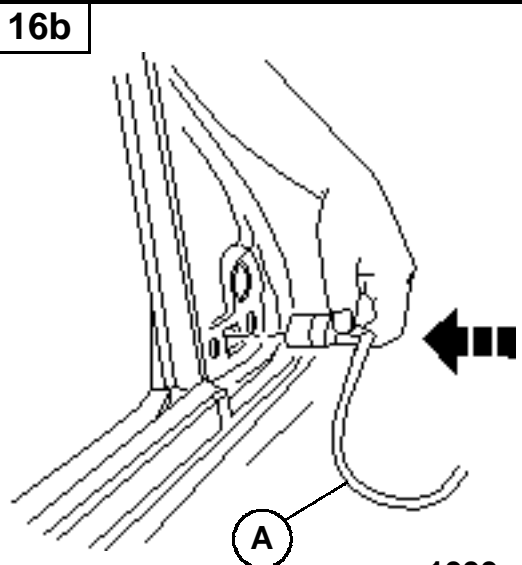

1999 - 2001

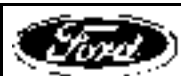

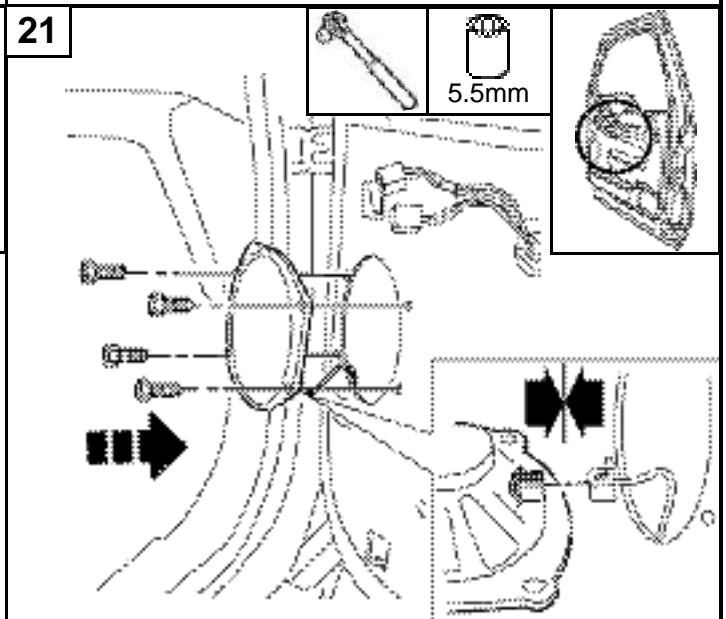
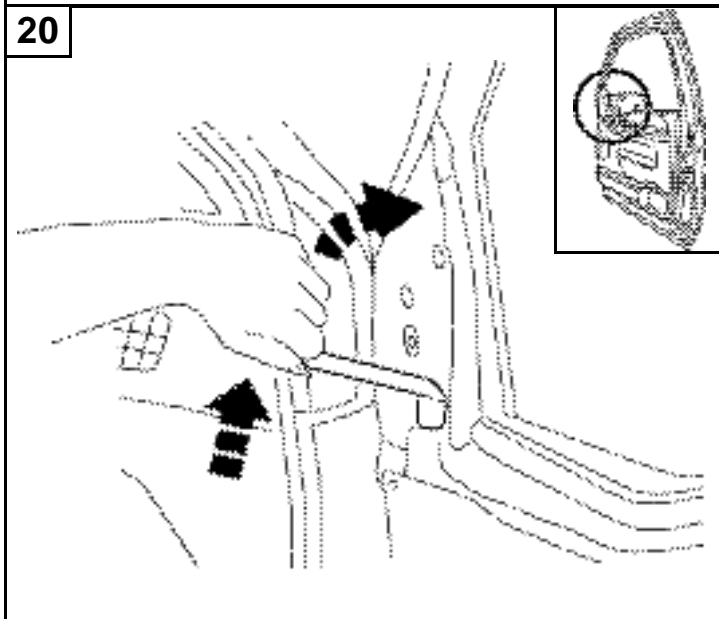
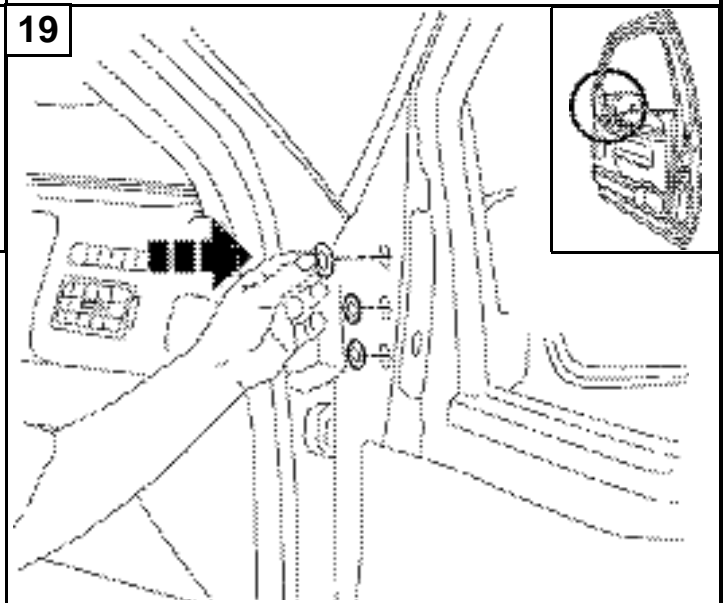
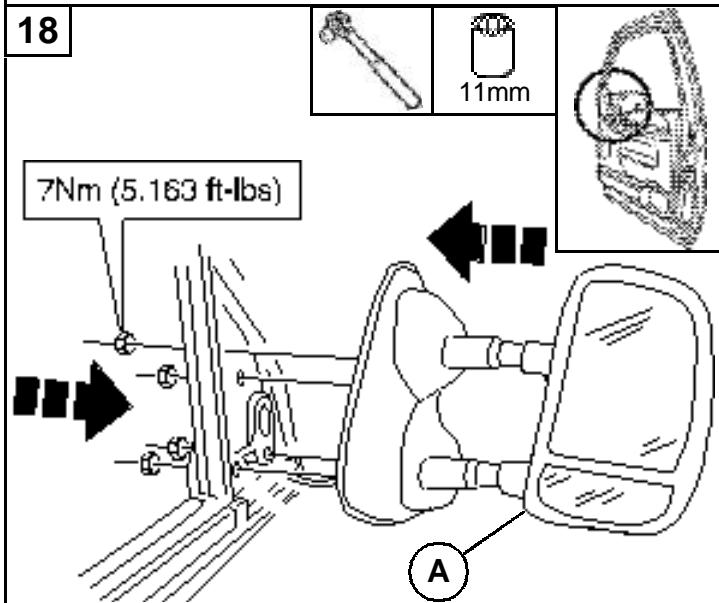
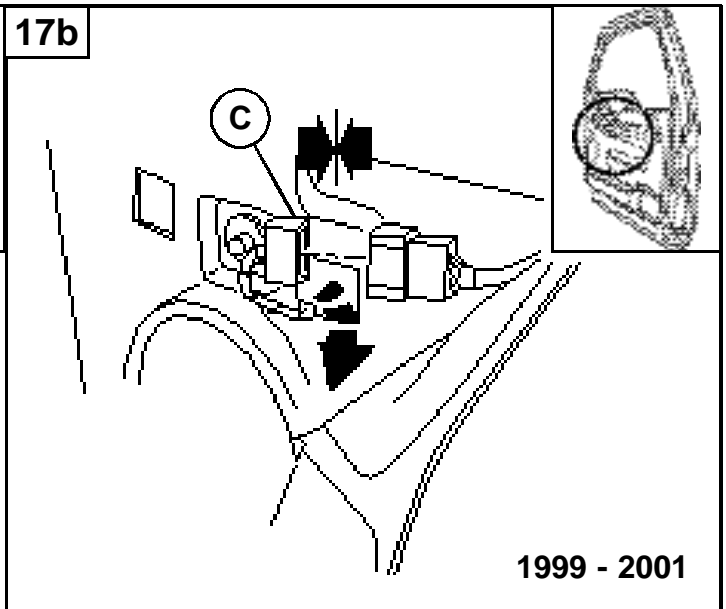
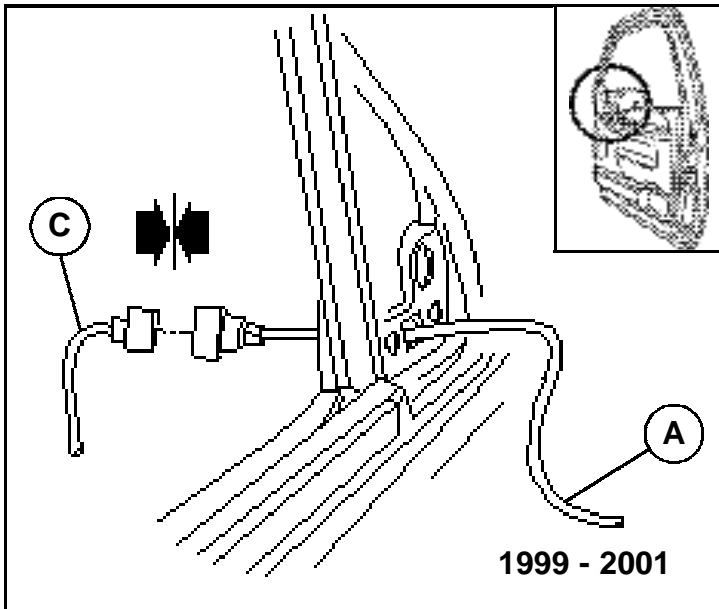

22

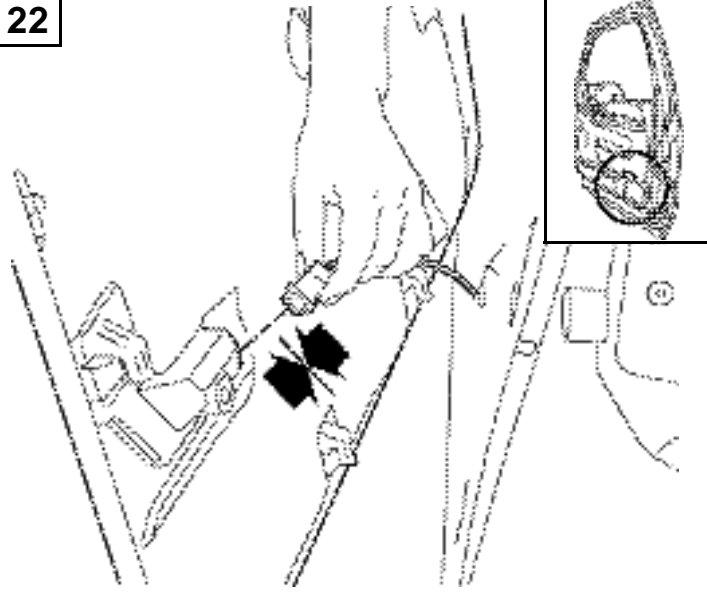

23

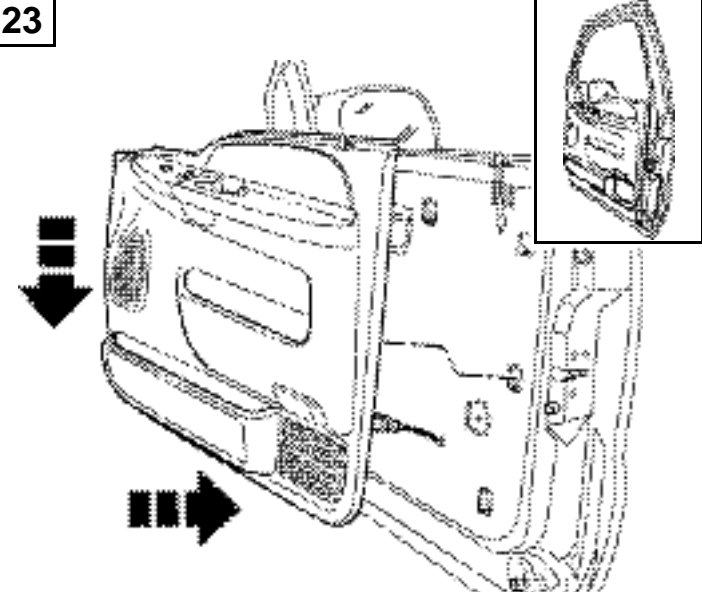

24

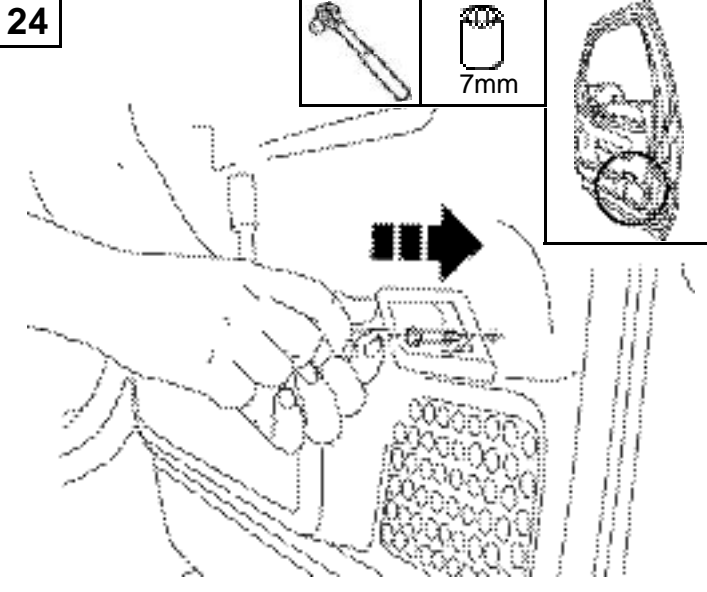

25

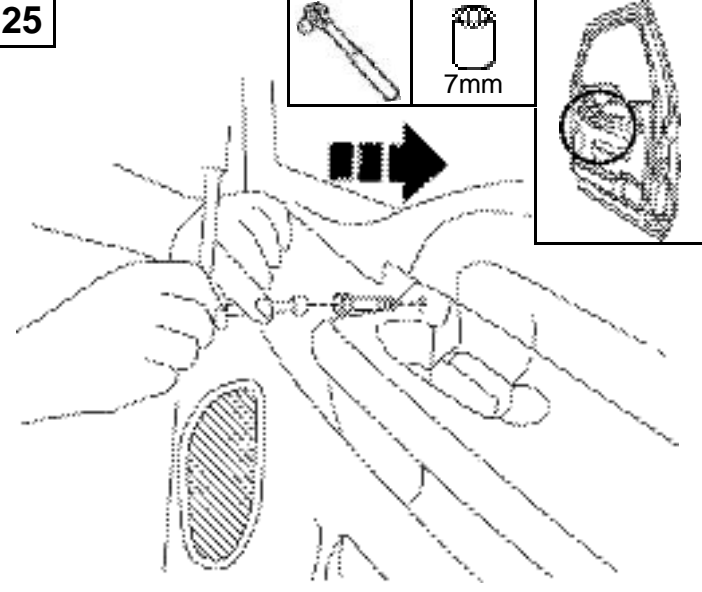

26

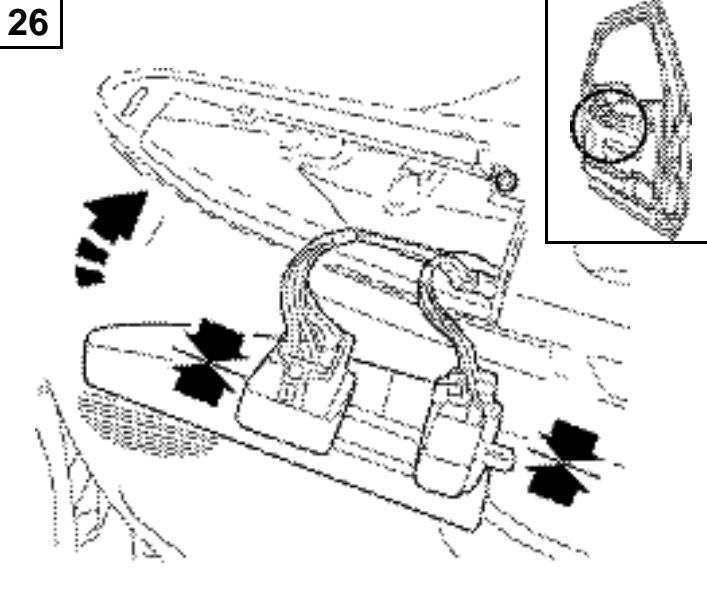

27

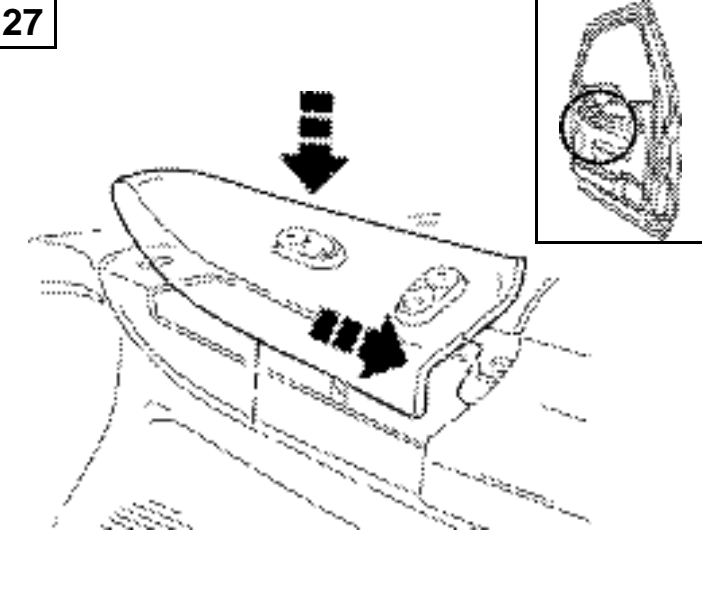

28

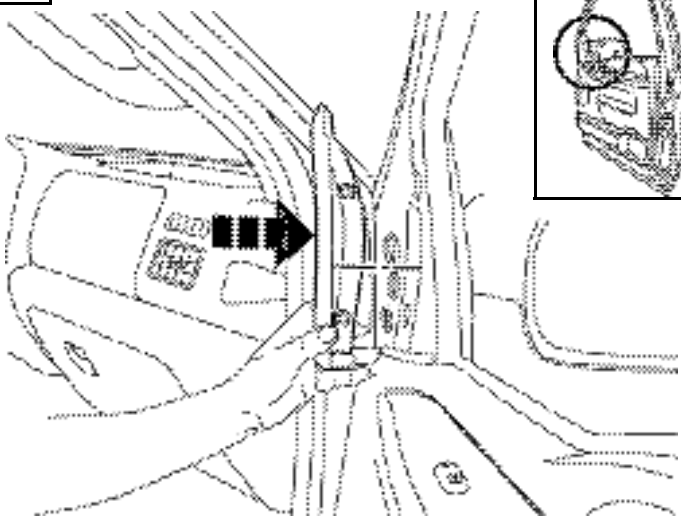

29

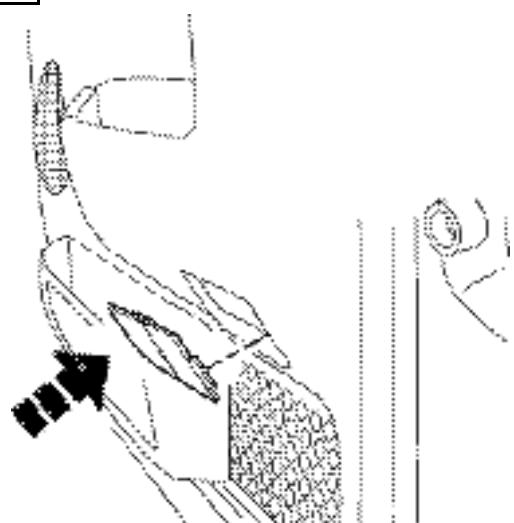

30

